

# GPX RANGE

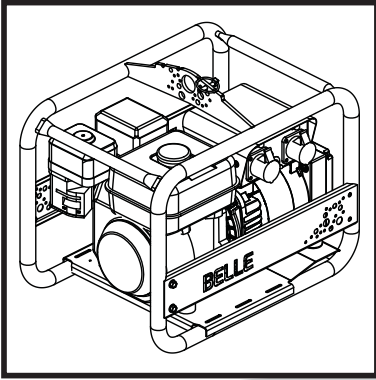

Ⓜ GB Operators Manual

4

1. Choke lever.
2. Fuel ON / OFF lever.
3. Engine ON / OFF switch.
4. Air Filter Housing.
5. Fuel Tank.
6. Exhaust.
7. Lifting Point.
8. Socket.
9. Alternator.
10. Voltage Switch
11. Circuit Breaker.
12. Earth
13. Securing Pin (for use when stacking machines)

(Diagram based on the GPX 3400 Generator)

### Switch Box Rear View

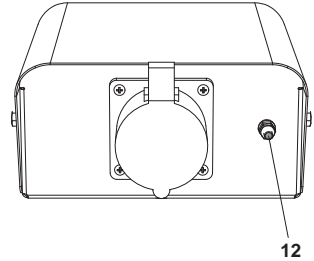

### Switch Box Front View

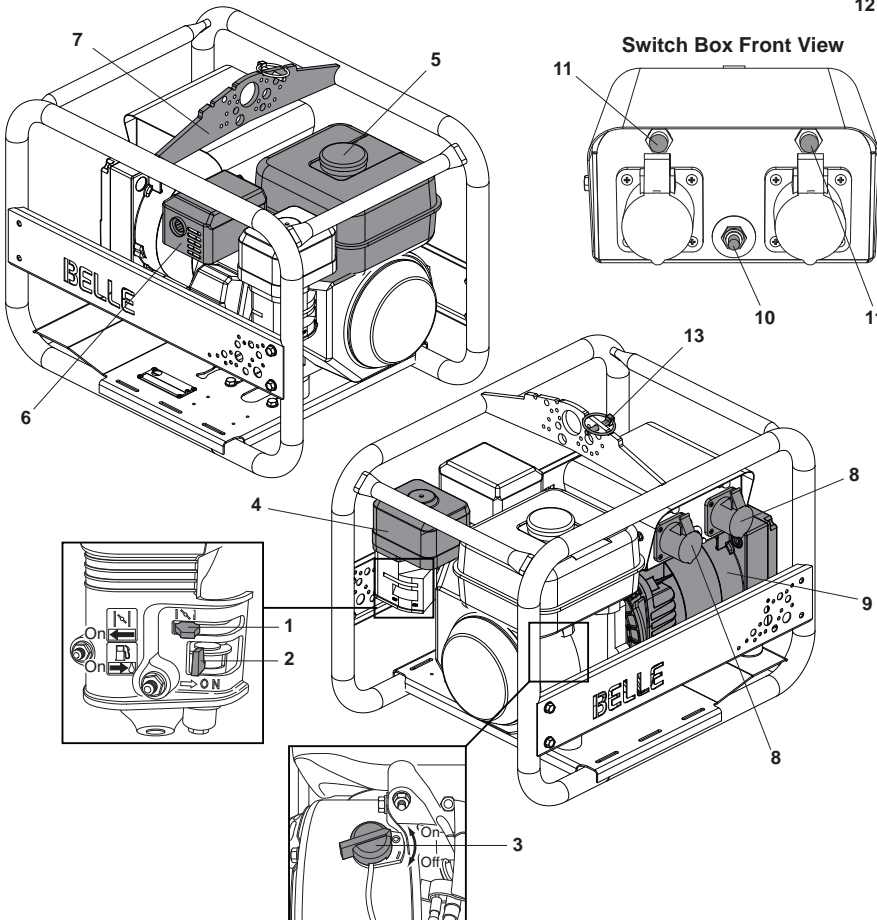
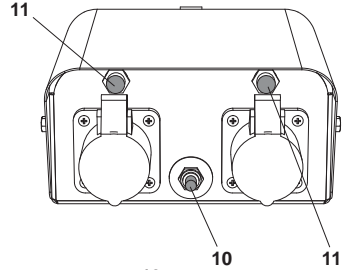



## Technical Data

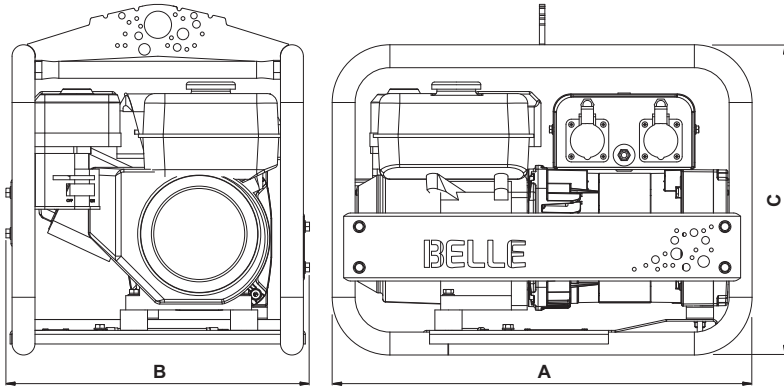

Model	GPX 2700	GPX 3400	GPX 5000
A - Overall Length (mm)	618	618	728
B - Overall Width (mm)	432	432	512
C - Overall Height (mm)	515	515	595
Weight (Kg)	46	47	64
Rating @0.8 p/f (kVA)	2.7	3.4	5.0
PRP Rating (kW)	2.2	2.7	4.0
COP Rating (kW)	2.0	2.5	3.6
Engine Power @3000rpm (kW / Hp)	4.3 / 3.3	4.3 / 3.3	6.2 / 4.6
Alternator	NSM K100 Range		
Frequency (Hz)	50	50	50
Phase	1	1	1
Maximum Current @ 110v	20.00	24.5	36.4
Maximum Current @ 230V	9.57	11.7	17.4
Fuel Tank Capacity (Ltr)	3.1	3.1	5.6
Running hours at @ 90% of COP (Hrs)	2.5	2.3	2.8
No. of 110v 16 amp sockets	1	1	2
No. of 230v 16 amp sockets	1	1	1
No. of 110v 32 amp sockets	-	1	1
Sound Power Level LWA	95	95	96

The above have a 2 pole 3000 r/min 50Hz 115/230V dual voltage alternator.  
All our generator ratings are based on a fully run in engine.



## Environment

### Safe Disposal.



Instructions for the protection of the environment. The machine contains valuable materials. Take the discarded apparatus and accessories to the relevant recycling facilities.

Component	Material
Main Frame	Steel
Chassis	Steel
Engine	Aluminium
Flexible Mounts	Steel and Rubber
Various Parts	Steel and Aluminium

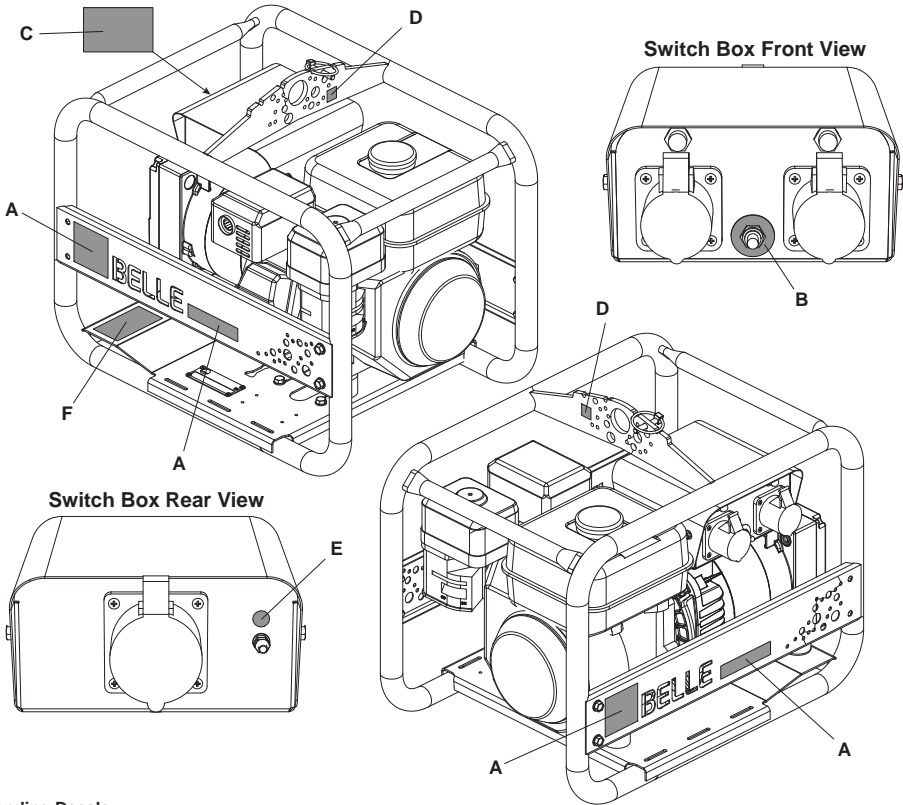

**A - Branding Decals**

Decals to identify the make and model of the machine.

**B - Voltage Switch Indicator Decal**

Decal to identify what voltage is selected.

**C - Rating Decal**

Decal to include main Technica Data, including Noise Level.

**D - Lifting Point Decal**

Identifies the Lifting Point.

**E - Earth Decal**

Identifies the position of the Earth point.

**F - Safety Decal**

General safety instructions for operating the machine.



Please Read  
Operators Manual



Wear Protective  
Footwear



Wear Ear  
Protection



Wear Eye  
Protection

For your own personal protection and for the safety of those around you, please read and ensure you fully understand the following safety information. It is the responsibility of the operator to ensure that he/she fully understands how to operate this equipment safely. If you are unsure about the safe and correct use of the Generator, consult your supervisor or Altrad Belle.

#### BEFORE STARTING THE GENERATOR



#### CAUTION

*Improper maintenance or use can be hazardous. Read and Understand this section before you perform any maintenance, service or repairs.*

- Suitable clothing as follows should meet relevant EEC/local standards: overalls, work boots and ear defenders.
- Become familiar with the controls before operating the machine.
- Place the generator on firm/level ground.
- Place the generator at least 1 metre away from buildings and other equipment during operation.
- The generator should be sheltered from the rain and water.
- Refuel in a well ventilated area with the engine switched off. Check for spilled fuel or leaks.
- Ensure all covers are fitted.
- Ensure that extension cables are carefully laid out avoiding liquids, sharp edges and places where vehicles might run over. Unroll it fully or it could catch fire.
- Replace any worn/damaged decals.
- Remove all packaging material before operating.

#### WHEN OPERATING THE GENERATOR

- Keep children and pets away from the generator.
- **DO NOT** run the generator in an enclosed area.
- Exhaust gases contain poisonous carbon monoxide.
- Adequate ventilation must be provided, to avoid serious overheating and subsequent damage to the windings.
- **DO NOT** operate the generator with wet hands, it is a potential source of electric shock.
- **DO NOT** operate the generator without correct instructions.
- **DO NOT** attempt to operate the generator in the snow and rain and do not let it get wet.
- **DO NOT** directly connect the generator to the domestic power sockets.
- **BEWARE** of hot surfaces.



#### CAUTION

*Fuel is flammable. It may cause injury and property damage. Shut down the engine, extinguish all open flames and do not smoke while filling the fuel tank. Always wipe up any spilled fuel.*

- Before refuelling, switch off the engine and allow it to cool.
- When refuelling, **DO NOT** smoke or allow naked flames in the area.
- Spilt fuel must be made safe immediately, using sand. If fuel is spilt on your clothes, change them.
- Store fuel in an approved, purpose made container away from heat and ignition sources.

#### SAFETY AND ACCIDENT PROTECTION

##### Operating Instructions:

All persons who apply, assemble, operate, start, control, maintain or repair this machine must read and understand these operating instructions.

##### Owner Responsibility:

The owner must ensure that only qualified persons operate, maintain, or repair this machine.

##### Storage:

When not in use, store in a dry, locked place. Keep away from children.

##### Operation for the Intended Purpose:

This generator is designed to generate electricity up to its stated maximum amperage loading, at the voltage stated on the appliance rating plate. Do not attempt to use it to do anything else. Do not use it in an explosive atmosphere.

##### Transport :

Refer to the engine and alternator manuals provided for full transport recommendations.



## **WARNING**

*Before you operate or carry out any maintenance on this machine **YOU MUST READ** and **STUDY** this manual.*

### **PRE-OPERATION**

- Check your generator before use and **IMMEDIATELY** replace any damaged parts.
- Place the generator on firm level ground with the engine switched **OFF**.
- Check the engine oil level, low oil levels will result in the engine not starting.
- Check the fuel level.
- Check the electrical installation according to the usage.
- Check the earth cable. Replace **IMMEDIATELY** if damaged.
- This equipment is likely to emit a Sound Power Level (LWA) of up to 96dB(A). Wear appropriate ear defenders.
- Your Altrad Belle generator comes preset and **NO** adjustment is necessary.
- Be aware of how to stop the generator by use of the ignition switch.

Refer to the engine and alternator manuals provided for full pre-operation check.

### **STOPPING**

- Switch **OFF** the loads.
- Switch **OFF** the engine.
- Turn the fuel tap to the **CLOSED** position.

### **STARTING - HONDA GX200 / GX270**

- Switch **OFF** all electrical appliances connected to the generator.
- Remove all objects placed on, or within one metre of the generator.
- Open the fuel tap by moving the fuel **ON / OFF** lever fully to the right.
- If starting the engine from cold, set the choke **ON** by moving the choke lever fully to the left. If restarting a warm engine, the choke is usually not required, however, if the engine has cooled to a degree, partial choke may be required.
- Turn the engine **ON / OFF** switch clockwise to the 'I' position.
- Set the throttle to the idle position by moving the throttle lever fully to the right.
- Taking a firm hold of the control handle with one hand, grasp the recoil starter handle with the other. Pull the recoil starter until engine resistance is felt, then let starter return.
- Taking care not to pull the starter's rope fully out, pull the starter handle briskly.
- Repeat until the engine fires.
- Once the engine fires gradually set the choke lever to the **OFF** position by moving it to the right.
- If the engine fails to fire after several attempts, follow the Troubleshooting Guide.
- To stop the engine, set the throttle to idle and turn the engine **ON / OFF** switch anticlockwise to the '0' position.
- Turn the fuel **OFF**.
- Select required voltage.

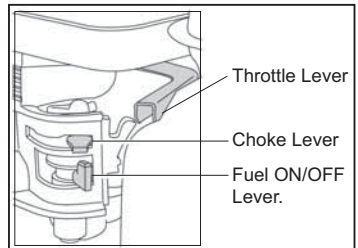

Your Altrad Belle generator is now ready for operation.

### **TREAT THE ELECTRICITY PRODUCED BY THIS GENERATOR AS YOU WOULD MAINS ELECTRICITY.**



## **CAUTION**

*The engine running speed is pre-set by the manufacturer and must not be adjusted.*

The engine speed governs the frequency of the electric supplied (50Hz in U.K.). If the speed is inadvertently disturbed the generator must immediately be stopped and not used until reset.

Damage to electrical appliances can occur if they are supplied with the wrong electrical frequency.

**OPERATION**

Electrical outputs will vary according to the model. Refer to the rating plate for full details and see the following section on component identification.

- 110v AC 16 amp use yellow socket.
- 230v AC 16 amp use blue socket.
- (110v AC 32 amp use yellow socket, 5 kVA & 6 kVA only).

**CAUTION**

*All our 230/110v dual voltage generators have 'floating' windings and are not referenced to frame or earth.*

**CAUTION**

*The third 'earth' socket pin of the BS4343 socket is connected to the frame. Ensure frame has sufficient ground connection at all times.*

**CAUTION**

*If installing a generator into a domestic mains supply for use as a secondary back up, this connection must be done by a qualified competent electrician to ensure correct earthing and installation to the IEE Regulations for Electrical installations or your regional electrical regulations.*

**CAUTION**

*It is recommended that all electrical connections, including earth, are checked and inspected at regular intervals.*

The engine is fitted with an oil alert switch that will automatically stop the engine if there is a fault in the oil system.

**Circuit Breaker**

In case of accidental overload the generator is protected by circuit breakers, thus protecting the generator windings by limiting the current drawn at the preset level. This type of circuit breaker offers improved protection to the generator and any appliance being used.

However this type of breaker offers no earth leakage protection but will trip-in in case of a dead short that produces a current 25% above the circuit breaker rating. The breaker has a delay action that allows current surges, often required when starting electrical motors. The delay of the circuit breaker is designed so that if the current required is too great eg. too large a motor, the supply will cut off.

Be careful to ensure that appliances do not exceed 15% of the generators rated load capacity for more than 10 minutes in the hour. A substantial overload will switch off the circuit breaker. Marginal overload will not switch off the circuit breaker but will shorten the generators service life.

Be sure that all electrical appliances are safe before connecting to the generator. If an appliance fails or stops, switch off the load and engine. Examine the appliance for signs of malfunction.

## ESTIMATING POWER CONSUMPTION

Identifying the correct generator for an application is not always straight forward. There is often difficulty determining the actual power requirements to both start and run the expected load(s). A generator should be considered capable if it can operate within the frequency and voltage specification, for one second after it begins to power the appliance. Some appliances, especially electric motors, may overheat or become damaged by prolonged or repeated connection to a power source, which is insufficient to start them. The two important factors to remember are:

- 1) Ensure the total load does not exceed the generators rated continuous output, for more than 30 minutes.
- 2) Never exceed the generator's maximum output specification.

The best way to ensure that neither of the above occurs is to contact the manufacturer of the equipment that is intended for use with the generator. Alternatively a useful way to measure the starting and running current for the appliance is to use a Altrad Belle Minigen meter. The unit can monitor volts, amps and frequency to help guarantee the performance of both the generator and tools. If it is not possible to test the appliance, then the following information will allow the size of the generator required to be estimated.

### RESISTANCE TYPE LOADS

Examples: Light bulbs, toasters, hair dryers, coffee pots, irons and other appliances, which have heating elements. This type of load is usually rated in watts, but sometimes a combination of watts and amps will be given. It is possible to select a suitable generator by comparing the specification of the generator with the generator output specification.

**Method 1:** Use when load is rated in watts.

$$\frac{\text{Indicated wattage of resistance type load}}{\text{Power factor for resistance}} = \frac{\text{Watt}}{1} = \text{VA} = \text{Required Generator Output}$$

**Method 2:** Use when voltage and measured current are known.

$$\text{Specified voltage of the resistance type load} \times \text{Measure current of the resistance type load} = \text{VA} = \text{Required Generator Output}$$

### INDUCTIVE AND CAPACITIVE TYPE LOADS:

Examples: Appliances or tools with electric motors, air conditioners, microwave ovens, televisions, fluorescent lights and any other appliances that are not simply resistance type loads.

This type of appliance (especially those that use electric motors) may require more power to start then is indicated by their running power ratings. It is not possible to select a generator by the power rating information given on the appliance; it is necessary to know both the starting current and running current required.

Running power requirements:

**Method 1:** Use when load is rated in watts.

$$\frac{\text{Indicated wattage of inductive/capacitive load}}{\text{Indicated Power factor}} = \frac{\text{Watt}}{<1} = \text{VA} = \text{Required Generator Output}$$

**Method 2:** Use when voltage and measured current are known.

$$\text{Specified voltage of the inductive/capacitive load} \times \text{Measure current of the inductive/capacitive type load} = \text{VA} = \text{Required Generator Output}$$

Starting power requirements:

**Method 1:** Use when starting current and voltage are specified.

$$\text{Indicated starting current} \times \text{Specified voltage of the inductive/capacitive load} = \text{VA} = \text{Starting power requirements}$$

**Method 2:** Use when starting current and voltage are specified.

$$\text{Measured starting current} \times \text{Specified voltage of the inductive/capacitive load} = \text{VA} = \text{Starting power requirements}$$



## GENERAL GUIDELINES

Refrigerators, freezers, compressors and central heating pumps usually have induction type motors and the starting current can be three times higher than the running current.

Fluorescent lamps require approx 1.5 times their stated wattage to start-up.

Microwave ovens are often referred to by their cooking power, which is often half the operating power. Starting up the oven consumes an extra 25%, which is used to energise the capacitor. This means that a microwave rated at 600 Watts (cooking power) actually needs 1500 watts to operate it.

It is essential to consult the manufacturer when considering using electric welders.

## Examples

a) Kettle (Specification: 230V 50Hz, 2200W, unknown Amps) - Resistance load

$\frac{\text{Indicated wattage of resistance type load}}{\text{Power factor for resistance}} = \frac{2200}{1} = 2200 \text{ VA or } 2.2\text{kVA to operator}$
--

b) Mini 150 concrete mixer (Specification: 110V 50Hz, 600W, 5.5A) - Inductive / Capacitive load

$\frac{\text{Specified voltage of the inductive/capacitive load}}{\text{inductive/capacitive load}} \times \frac{\text{Measured current of the inductive/capacitive load}}{\text{inductive/capacitive load}} = 110 \times 5.5 = 605 \text{ VA or } 0.605 \text{ kVA to operate}$
--

The power required to start the mixer is actually 3 x this amount, therefore: 3 x 0.605kVA = 1.815 kVA to start the machine.

# Servicing



Before starting any maintenance or repairs, stop engine or switch off motor, and isolate from the main power supply. On completion of maintenance, check that the generator functions correctly and that all guards are correctly fitted.

## EXTENSION CABLES

If you need to use an extension cable it must be no longer than 30 metres (100 feet) in length. Ensure that the extension cable is carefully laid out avoiding liquids, sharp edges and places where vehicles might run over it or become trapped. Unroll it fully or it will overheat and could catch fire. Make sure that any extension cable connections are dry and safe.

## COMBUSTION ENGINES



**CAUTION** *Be aware of exhaust venting directions.*

The engine needs a regular oil check. Try not to run low on fuel as this may result in sediment from the bottom of the tank doing damage to the injector and pump. **Repairs and rectification of pipework and components affected by contaminants in fuel cannot be accepted as warranty, neither will faults caused or contributed to by the machine running out of fuel.** You may need to bleed the fuel system free of air before starting. For initial engine fill or top up use a suitable engine oil of a 10W/30 grade. In your own interests read the makers instruction leaflet issued with the machine before starting up.

## LUBRICATION AND RUNNING

See Maintenance Schedule Section and Operating Instructions.

# Maintenance Schedule



Only authorised dealers should repair the generator, and within the requirements of the CE mark (where applicable), where no deviation from the original specification must take place.

Please refer to the Engine Manufacturers instruction leaflet, before attempting any maintenance checks or procedures.



**CAUTION** *Any maintenance and repairs carried out, to any part of the electrical circuit, must be undertaken by a qualified electrician.*



**CAUTION** *Disable engine starting circuits before carrying out any maintenance or repair.*

Routine Maintenance		Each Use	First Month / 20 Hours	3 Months / 50 Hours	6 Months / 100 Hours	Yearly / 300 Hours
Engine Oil	Check Level	✓				
	Change		✓		✓	
Air Cleaner	Check	✓				
	Clean			✓ (1)		
Sediment Cup	Clean				✓	
Spark Plug	Check - Clean				✓	
Valve Clearance	Check - Adjust					✓ (2)
Fuel Tank & Strainer	Clean					✓ (2)
Fuel Line	Check (Replace if necessary)		Every 2 Years (2)			

(1): Service more frequently when in dusty areas.

(2): These items should be serviced by an authorised Honda dealer.

Problem	Cause	Remedy
Engine will not start.	Fuel tap not turned on.	Turn fuel on.
	No fuel in tank.	Fill fuel tank.
	Oil not filled to correct level.	Fill oil to correct level.
	Engine run switch not turned on.	Set engine control correctly.
	Choke not set correctly.	Set engine control correctly.
	Spark plug fouled.	Replace / clean spark plug.
	Air cleaner blocked.	Replace / clean air filter.
Engine still will not start.	Major Fault	Contact Agent or Altrad Belle.
Engine runs rough.	Air cleaner blocked.	Replace / clean air filter.
	Spark plug fouled.	Replace / clean spark plug.
	Choke set incorrectly.	Set engine control correctly.
	Dirty / stale fuel.	Drain and replace fuel.
No electrical output.	Voltage selector switch incorrectly positioned.	Select the correct voltage.
	Circuit breaker tripped.	Re-set circuit breaker.

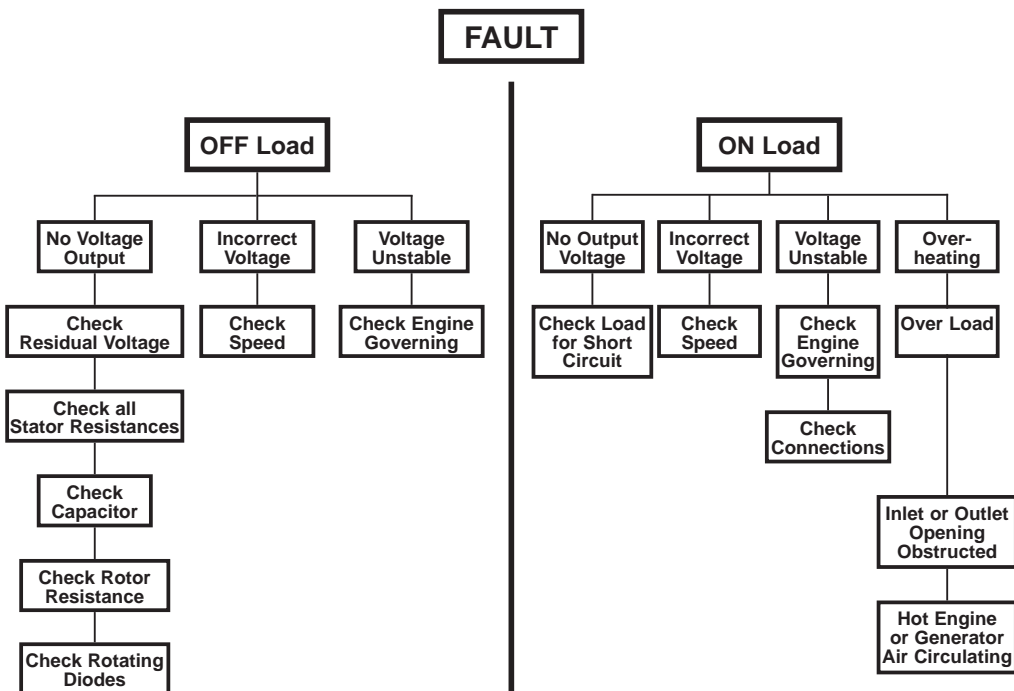

## Circuit Breaker Specifications



kVA	110v	230v
2.7	20	9
3.4	25	12
5.0	35	20

## Capacitor Chart



kVA	Replacement Capacitor Required
2.7	14 $\mu f$
3.4	14 $\mu f$
5.0	30 $\mu f$

## Application



Before deciding which generator you need, it is important to consider **ALL** the appliances you will be operating, how many will be used simultaneously and the **TOTAL** current consumption at any one time. Most appliances have a description plate stating the current, usually in watts.

### IMPORTANT

TV sets, cookers HI-Fi, kettles and filament lamps have resistive loads, their starting and running current being virtually the same, and as stated on the description plate. Fluorescent lamps (on average) require approximately 1.5 times their stated wattage to start-up. Hand tools with universal-type motors need an extra 5% added to their stated power consumption.

Altrad Belle Mini/Maxi concrete mixers, refrigerators, vacuum cleaners, freezers and central heating pumps usually employ induction/capacitor type motors. Their starting current can be three times the normal running requirement: check the description plate carefully. Note for example, a Altrad Belle Mini 140 and 150 mixer, having a motor wattage of 650 watts input multiplied by three would give a total starting requirement of 1950 watts, therefore a 2.2 kw Altrad Belle generator would be required.

If in doubt, check with the appliance manufacturer. Microwave ovens are often referred to by their cooking power, which on average is half their actual operating power consumption. However, switching on the oven consumes an extra 25% power as the capacitor is energised. Thus, a normal '600 watt' microwave oven actually needs 1500 watts to operate it.

### TYPICAL CURRENT CONSUMPTION

The following is presented as an approximate guide to the power requirements including start up when applicable.

## GPX 2700

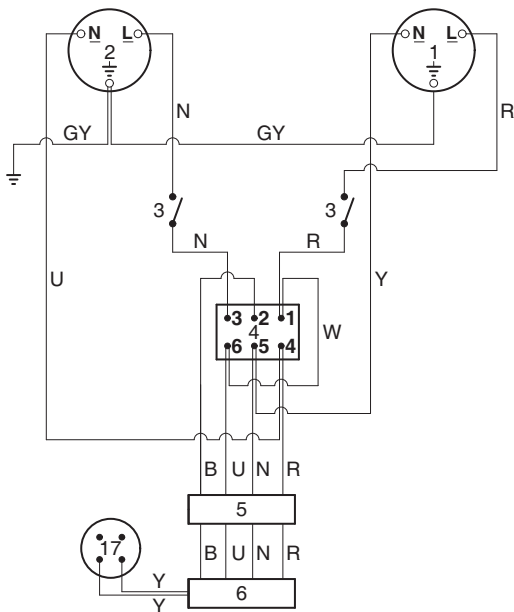

## GPX 3400

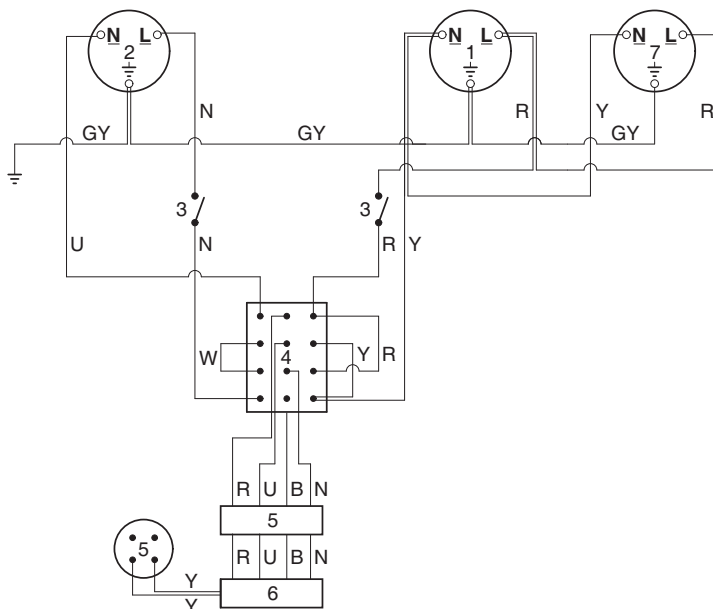

## GPX 5000

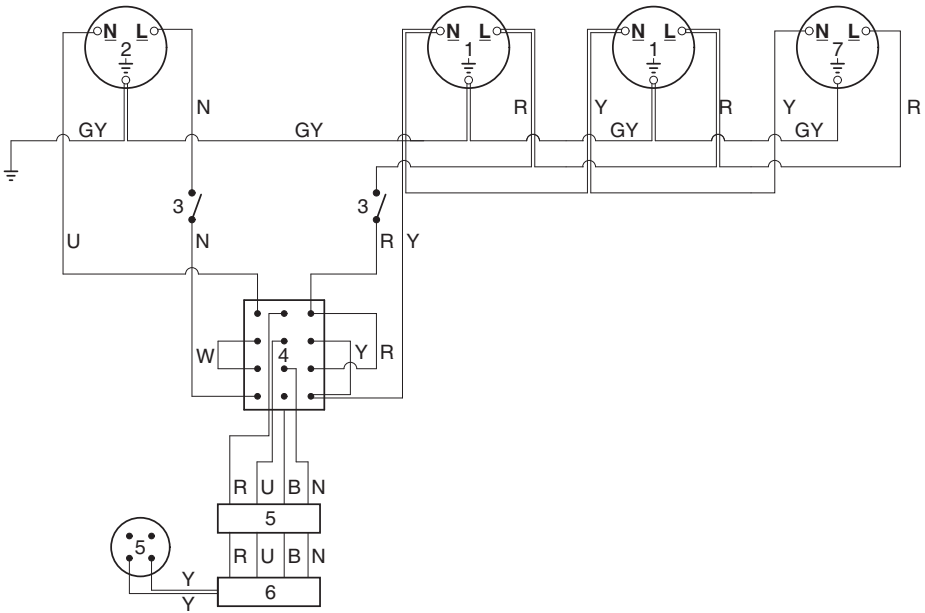

### KEY

- N** - Brown
- U** - Blue
- G/Y** - Green/Yellow
- W** - White
- R** - Red
- Y** - Yellow
- B** - Black
- 1** - 115v Socket (16 amp)
- 2** - 230v Socket (16 amp)
- 3** - Circuit Breaker
- 4** - Change Over Switch
- 5** - Connector Block Alternator
- 6** - Alternator
- 7** - 115v Socket (32amp)
- 17** - Capacitor
- N** - Neutral
- L** - Live

Your new Altrad Belle Generator is warranted to the original purchaser for a period of one-year (12 months) from the original date of purchase. The Altrad Belle warranty is against defects in design, materials and workmanship.

The following are not covered under the Altrad Belle warranty:

1. Damage caused by abuse, misuse, dropping or other similar damage caused by or as a result of failure to follow assembly, operation or user maintenance instructions.
2. Alterations, additions or repairs carried out by persons other than Altrad Belle or their recognised agents.
3. Transportation or shipment costs to and from Altrad Belle or their recognised agents, for repair or assessment against a warranty claim, on any machine.
4. Materials and/or labour costs to renew, repair or replace components due to fair wear and tear.

The following components are not covered by warranty.

- Drivebelt/s
- Engine air filter
- Engine spark plug

Altrad Belle and/or their recognised agents, directors, employees or insurers will not be held liable for consequential or other damages, losses or expenses in connection with or by reason of or the inability to use the machine for any purpose.

### Warranty Claims

All warranty claims should firstly be directed to Altrad Belle, either by telephone, by Fax, by Email, or in writing.

#### For warranty claims:

Tel: +44 (0)1298 84606

Fax: +44 (0)1298 84073

Email : [Warranty@belle-group.co.uk](mailto:Warranty@belle-group.co.uk)

#### Write to:

Altrad Belle Warranty Department,  
Sheen, Nr. Buxton,  
Derbyshire,  
SK17 0EU  
England.

#### Warranty Registration:

In the bid for ALTRAD Belle to become greener and more eco friendly, we have now introduced online Warranty registration. To access the registration page of our website, please use the following address:-

[http://www.bellegroup.com/index.php?p=warranty\\_registration](http://www.bellegroup.com/index.php?p=warranty_registration)

Alternatively, please scan the adjacent QR Code (Quick Response Code) using your smartphone to access the registration page.







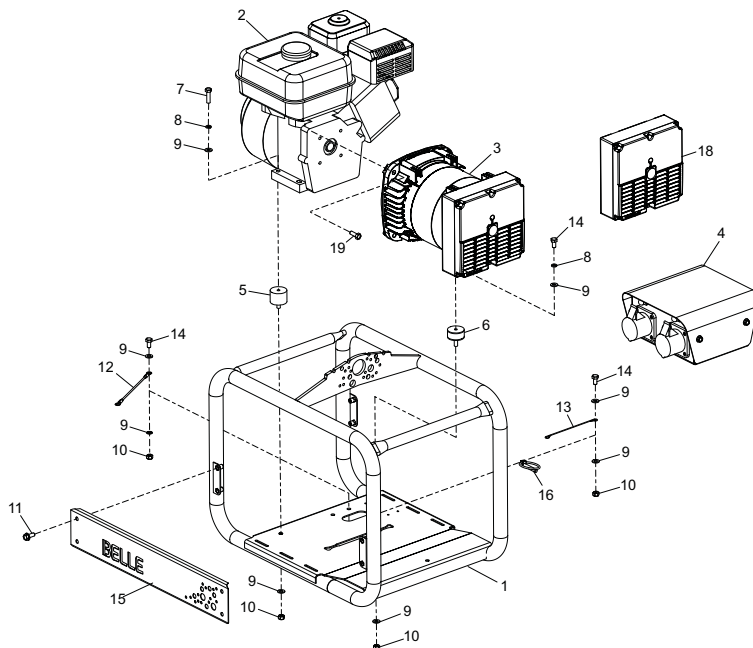

### Main Assembly - GPX 2700 & 3400

1	996/00400SP	..... Frame .....	1
2	20/0132	..... Engine.....	Honda GX200..... 1
3	996/01500	..... Alternator.....	1
4	See 2-01	..... Control Box.....	GPX 2700..... 1
5	See 2-02	..... Control Box.....	GPX 3400..... 1
5	21/0157	..... Anti-Vibration Mount .....	2
6	21/0436	..... Anti-Vibration Mount .....	2
7	7/8009	..... Screw .....	M8 x 30..... 2
8	4/8003	..... Washer .....	M8..... 4
9	4/8006	..... Washer .....	M8..... 11
10	8/8008	..... Nut .....	M8..... 6
11	7/8037	..... Screw .....	M8 x 20..... 8
12	71/0316	..... Earth Cable.....	1
13	914/25303	..... Retaining Cable .....	1
14	7/8008	..... Screw .....	M8 x 16..... 4
15	996/99906S	..... Side Guard.....	Orange..... 2
15	996/99906B	..... Side Guard.....	Blue..... 2
15	996/99906G	..... Side Guard.....	Green..... 2
15	996/99906R	..... Side Guard.....	Red..... 2
15	996/99906Y	..... Side Guard.....	Yellow..... 2
15	996/99906W	..... Side Guard.....	White..... 2
16	3/1007	..... Lynch Pin.....	1
17	71/0316	..... Earth Cable.....	1
18	996/99910	..... Alternator Cover.....	1
19	9/0005	..... Screw.....	5/16 x 7/8..... 4

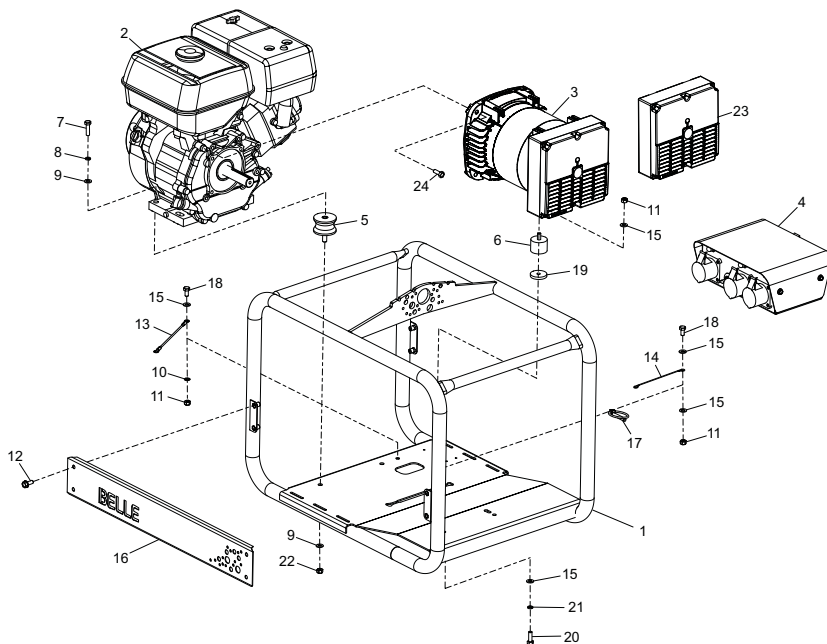

## Main Assembly - GPX 5000

1	996/00600SP	..... Frame .....	1
2	20/0133	..... Engine.....	Honda GX270..... 1
3	996/01700	..... Alternator .....	1
4	See 2-03	..... Control Box.....	1
5	21.0.292	..... Anti-Vibration Mount .....	2
6	21/0157	..... Anti-Vibration Mount .....	2
7	7/10010	..... Screw.....	M10 x 30..... 2
8	4/1003	..... Washer .....	M10..... 2
9	4/1005	..... Washer .....	M10..... 4
10	4/8002	..... Washer .....	M8..... 1
11	8/8008	..... Nut .....	M8..... 4
12	7/8037	..... Screw.....	M8 x 20..... 8
13	71/0317	..... Earth Cable.....	1
14	914/25303	..... Retaining Cable .....	1
15	4/8006	..... Washer .....	M8..... 7
16	996/99907S	..... Side Guard.....	Orange..... 2
16	996/99907B	..... Side Guard.....	Blue..... 2
16	996/99907G	..... Side Guard.....	Green..... 2
16	996/99907R	..... Side Guard.....	Red..... 2
16	996/99907Y	..... Side Guard.....	Yellow..... 2
16	996/99907W	..... Side Guard.....	White..... 2
17	3/1007	..... Lynch Pin.....	1
18	7/8008	..... Screw .....	M8 x 16..... 2
19	4/8023	..... Washer .....	M8 x 40..... 2
20	7/8012	..... Screw.....	M8 x 25..... 2
21	4/8003	..... Washer .....	M8..... 2
22	8/10006	..... Nut.....	M10..... 2
23	996/99910	..... Alternator Cover.....	1
24	10-342-0616P	..... Screw.....	5/16 x 7/8..... 4

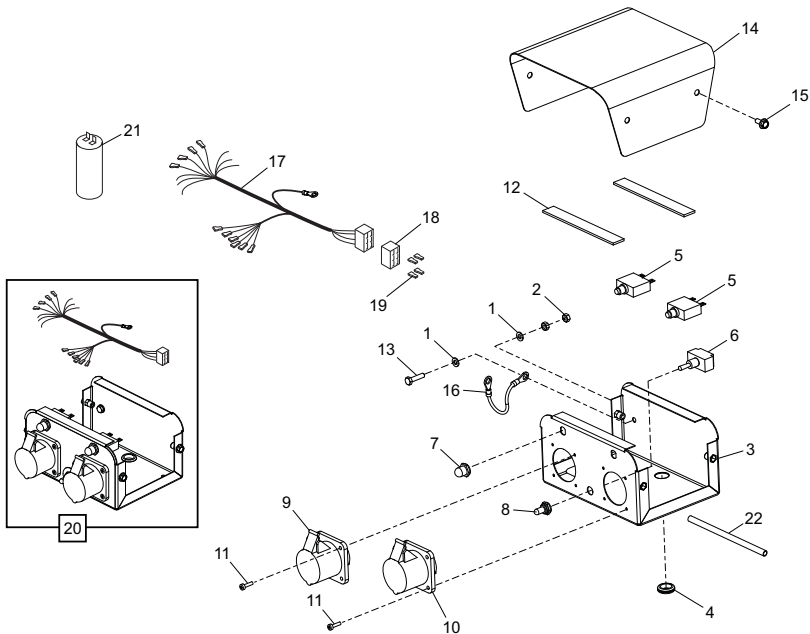

**Control Box - GPX 2700**

1	4/6001	..... Washer .....	M6 .....	2
2	8/6001	..... Nut .....	M6 .....	2
3	996/00301SP	..... Control Box Cover .....		1
4	3/4019	..... Grommet .....		1
5	918/40100	..... Circuit Breaker .....	20 Amp .....	2
6	918/13000	..... Switch 2-Pole .....		1
7	70/0314	..... Breaker Switch Cover .....		2
8	70/0313	..... Pole Switch Cover .....		1
9	922/02100	..... Socket .....	230v - 16 Amp .....	1
10	922/02000	..... Socket .....	110v - 16 Amp .....	1
11	7/4003	..... Screw .....	M4 x 16 .....	8
12	1/0817	..... Sealant Strip .....		2
13	7/6051	..... Screw .....	M6 x 25 .....	1
14	996/99902S	..... Control Box Cover .....	Orange .....	1
14	996/99902B	..... Control Box Cover .....	Blue .....	1
14	996/99902G	..... Control Box Cover .....	Green .....	1
14	996/99902R	..... Control Box Cover .....	Red .....	1
14	996/99902Y	..... Control Box Cover .....	Yellow .....	1
14	996/99902W	..... Control Box Cover .....	White .....	1
15	7/6034	..... Screw .....	M6 x 16 .....	4
16	71/0315	..... Earth Cable .....		1
17	71/0318	..... Harness .....		1
18	918/18500	..... Terminal Block .....		1
19	70/0321	..... Crimp Recepticle .....		4
20	996/01000SP	..... Control Box Complete .....		1
21	70/0326	..... Capacitor .....	14uf .....	1
22	1/1116	..... Heatshrink .....		1

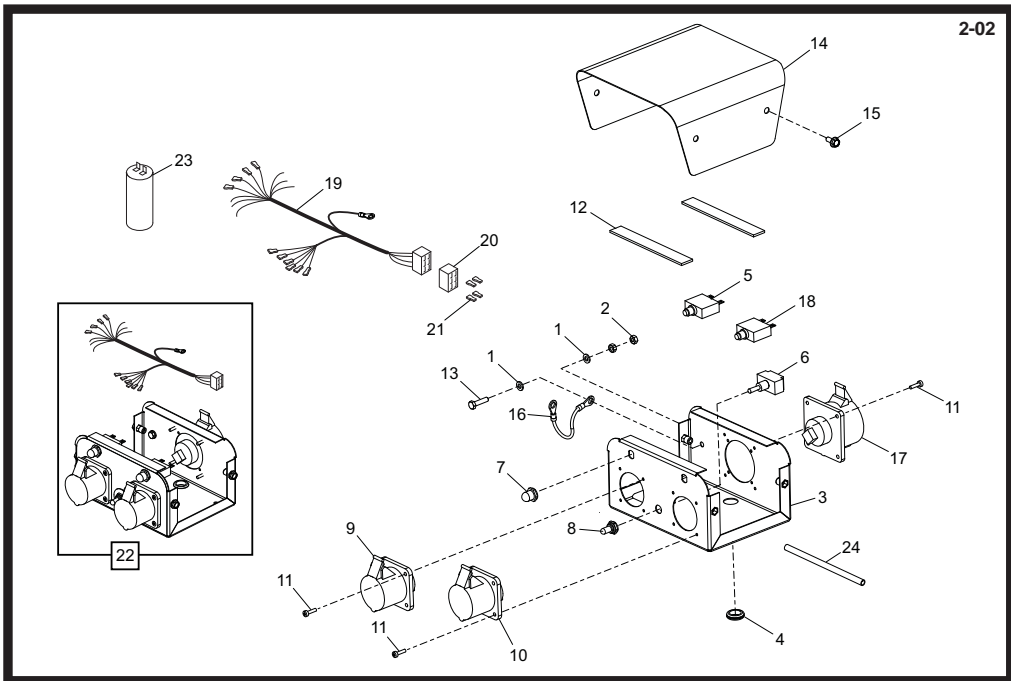

**Control Box - GPX 3400**

1	4/6001	Washer	M6	2
2	8/6001	Nut	M6	2
3	996/00501SP	Control Box Cover		1
4	3/4019	Grommet		1
5	918/39900	Circuit Breaker	12 Amp	2
6	918/13000	Switch 2-Pole		1
7	70/0314	Breaker Switch Cover		2
8	70/0313	Pole Switch Cover		1
9	922/02100	Socket	230v - 16 Amp	1
10	922/02000	Socket	110v - 16 Amp	1
11	7/4003	Screw	M4 x 16	8
12	1/0817	Sealant Strip		2
13	7/6051	Screw	M6 x 25	1
14	996/99902S	Control Box Cover	Orange	1
14	996/99902B	Control Box Cover	Blue	1
14	996/99902G	Control Box Cover	Green	1
14	996/99902R	Control Box Cover	Red	1
14	996/99902Y	Control Box Cover	Yellow	1
14	996/99902W	Control Box Cover	White	1
15	7/6034	Screw	M6 x 16	4
16	71/0315	Earth Cable		1
17	918/12900	Socket	110v - 32 Amp	1
18	918/40200	Circuit Breaker	25 Amp	2
19	71/0319	Harness		1
20	918/18500	Terminal Block		1
21	70/0321	Crimp Recepticle		4
22	996/01100SP	Control Box Complete		1
23	70/0326	Capacitor	14uf	1
24	1/1116	Heatshrink		1

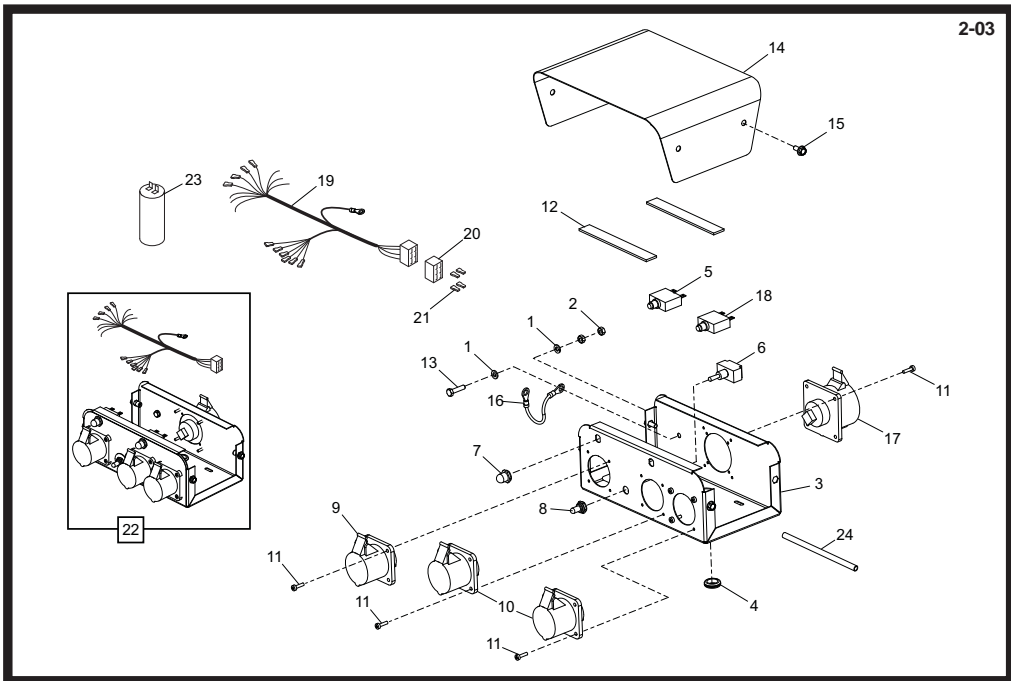

**Control Box - GPX 500**

1	4/6001	Washer	M6	2
2	8/6001	Nut	M6	2
3	996/00201SP	Control Box Cover		1
4	3/4019	Grommet		1
5	918/40100	Circuit Breaker	20 Amp	2
6	918/13000	Switch 2-Pole		1
7	70/0314	Breaker Switch Cover		2
8	70/0313	Pole Switch Cover		1
9	922/02100	Socket	230v - 16 Amp	1
10	922/02000	Socket	110v - 16 Amp	2
11	7/4003	Screw	M4 x 16	8
12	1/0817	Sealant Strip		2
13	7/6051	Screw	M6 x 25	1
14	996/99902	Control Box Cover		1
15	7/6034	Screw	M6 x 16	4
16	71/0315	Earth Cable		1
17	918/12900	Socket	110v - 32 Amp	1
18	918/42500	Circuit Breaker	35 Amp	1
19	71/0320	Harness		1
20	918/18500	Terminal Block		1
21	70/0321	Crimp Recepticle		4
22	996/01100SP	Control Box Complete		1
23	70/0327	Capacitor	16uf	1
24	1/1116	Heatshrink		1

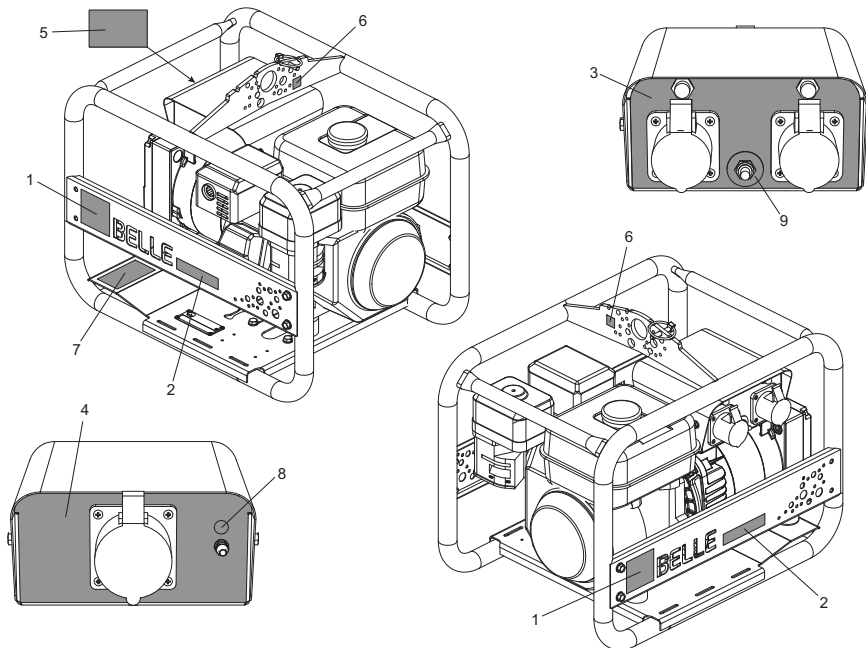

## Decals

1	800/99318.....	Decal.....	Altrad Logo.....	2
2	800/99322.....	Text Transfer.....	GPX 2700.....	2
2	800/99323.....	Text Transfer.....	GPX 3400.....	2
2	800/99324.....	Text Transfer.....	GPX 5000.....	2
3	800/99321.....	Decal.....	Box Front GPX 2700.....	1
3	800/99326.....	Decal.....	Box Front GPX 3400.....	1
3	800/99328.....	Decal.....	Box Front GPX 5000.....	1
4	800/99327.....	Decal.....	Box Rear GPX 3400.....	1
4	800/99329.....	Decal.....	Box Rear GPX 5000.....	1
5	800/99330.....	Decal.....	Rating GPX 2700.....	1
5	800/99331.....	Decal.....	Rating GPX 3400.....	1
5	800/99332.....	Decal.....	Rating GPX 5000.....	1
6	800/99334.....	Decal.....	Lifting.....	2
7	800/99333.....	Decal.....	Safety.....	1
8	800/99376.....	Deacl.....	Earth.....	1
9	800/99376.....	Decal.....	Voltage Indicator.....	1