

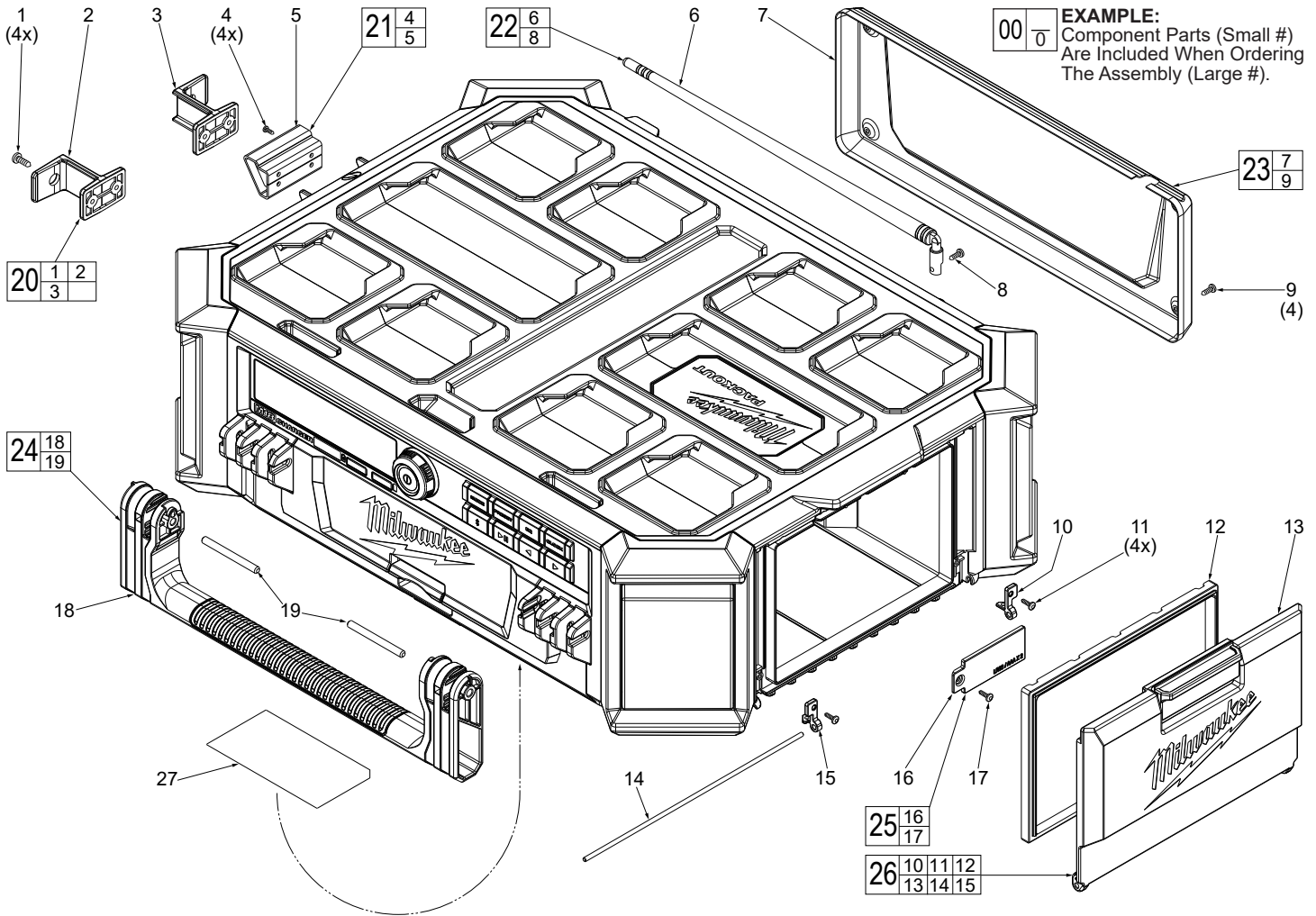

# SERVICE PARTS LIST



**EXAMPLE:**  
Component Parts (Small #)  
Are Included When Ordering  
The Assembly (Large #).

FIG.	PART NO.	DESCRIPTION OF PART	NO. REQ.
1	-----	PB3 x 12 Hd. Hex Screw	(4)
2	-----	Cord Wrap-Right	(1)
3	-----	Cord Wrap-Left	(1)
4	-----	PB3 x 12 Hd. Hex Screw	(4)
5	-----	Bottle Opener	(1)
6	-----	FM Antenna	(1)
7	-----	Rear Speaker Grill	(1)
8	-----	PM3 x 6mm Pan Hd. Phillips Screw	(1)
9	-----	PB3 x 12 Hd. Hex Screw	(4)
10	-----	Right Pivot Hinge	(1)
11	-----	PB3 x 10 Hd. Hex Screw	(4)
12	-----	Door Gasket	(1)
13	-----	M18™ Battery Door	(1)
14	-----	Hinge Rod	(1)
15	-----	Left Pivot Hinge	(1)
16	-----	AAA Battery Door	(1)
17	-----	PB3 x 10mm Pan Hd. Phillips Screw	(1)
18	-----	Front Handle	(1)
19	-----	Hinge Pin	(2)
20	42-38-0014	Cord Wrap Kit	(1)
21	14-46-0172	Bottle Opener Kit	(1)
22	42-09-0017	FM Antenna Assembly	(1)
23	43-52-0010	Rear Speaker Grill Kit	(1)
24	43-62-0063	Front Handle Kit	(1)
25	31-21-0029	AAA Battery Door Kit	(1)
26	31-21-0033	M18™ Battery Door Kit	(1)
27	12-20-0192	Service Nameplate	(1)

**FIG. 27 NOTES**  
A clean, dry surface is essential for proper performance for any adhesive system. The area intended for application of any adhesive label or nameplate must be prepared by cleaning with isopropyl alcohol. The solvent is to be applied with a clean, lint free applicator and the surface allowed to dry before applying the label or nameplate.