

TRAKER T60

MINIDUMPER

CAPACITÀ OPERATIVA
OPERATING WEIGHT
600 kg · 1323 lbs

LARGHEZZA AI CINGOLI
TRACK WIDTH
680 mm · 26.7 inch

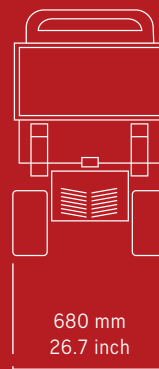
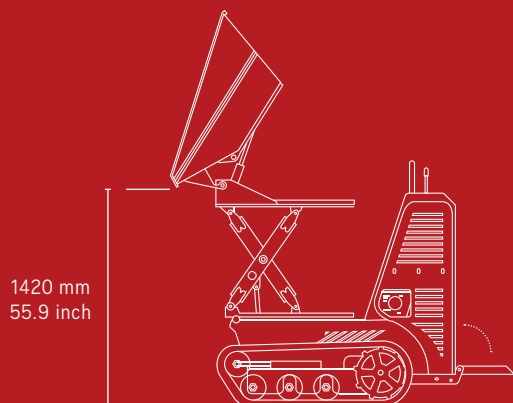
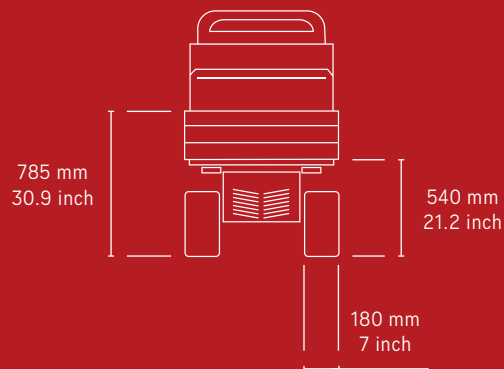
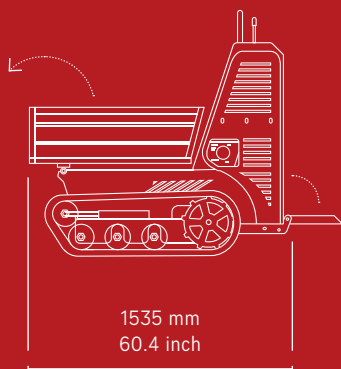
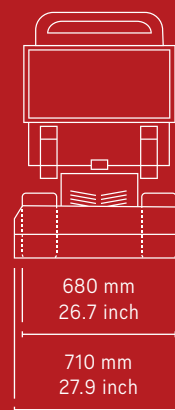
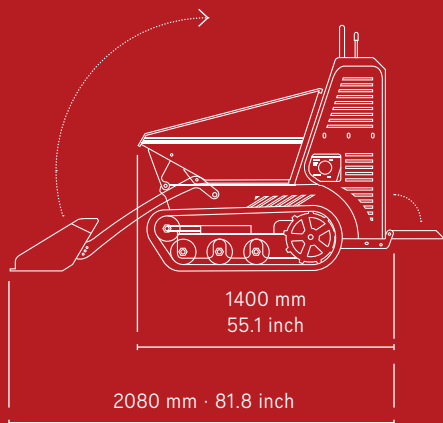

MOTORE TERMICO
ENGINE

- HONDA GX270
- YANMAR L70N

TRASMISSIONE
TRANSMISSION

- IDROSTATICA
- HYDROSTATIC

POMPA IDRAULICA
HYDRAULIC PUMP

- 3 X INGRANAGGI
- 3 X GEAR PUMP

MOTORE IDRAULICO
HYDRAULIC MOTOR

- 2 x ORBITALI
- 2 x ORBITAL

PORTATA POMPA
PUMP FLOW RATE

- 3 x 14 l/min
- 3 x 3,8 gpm

PRESSIONE MASSIMA
MAX PRESSURE

180 bar

RAFFREDDAMENTO IDRAULICO
HYDRAULIC COOLING SYSTEM

- ARIA
- AIR

LARGHEZZA CINGOLI
TRACK WIDTH

- 180 mm
- 7 inch

RULLI
TRACK ROLLERS

3

RULLI OSCILLANTI
ROCKING ROLLERS

- SI
- YES

REGOLAZIONE CINGOLI
TRACK TENSIONER

- SI
- YES

2 VELOCITÀ DI TRASLAZIONE
2 TRAVEL SPEED

- 2.5 – 3.5 km/h
- 1.55 – 2.2 mp/h

CAPACITÀ OPERATIVA
OPERATING WEIGHT

- 600 kg / 1323 lbs

HIGH-TIP

- 500 kg / 1102 lbs

MASSA A VUOTO
EMPTY WEIGHT

- 355 kg
- 749 lbs

CARATTERISTICHE TECNICHE / TECHNICAL FEATURES

 RASO 0.23 m³
STRUCK 0.28 yd³

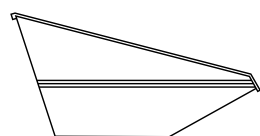

 COLMO 0.29 m³
HEAPED 0.37 yd³

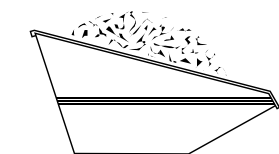

 RASO 0.15 m³
STRUCK 0.19 yd³

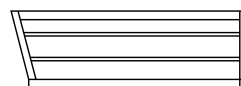

 COLMO 0.23 m³
HEAPED 0.30 yd³

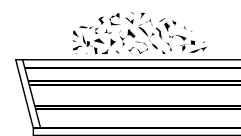

 RASO 0.18 m³
STRUCK 0.23 yd³



 COLMO 0.23 m³
HEAPED 0.30 yd³

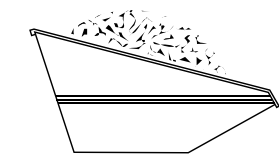

CAPACITÀ / CAPACITY